

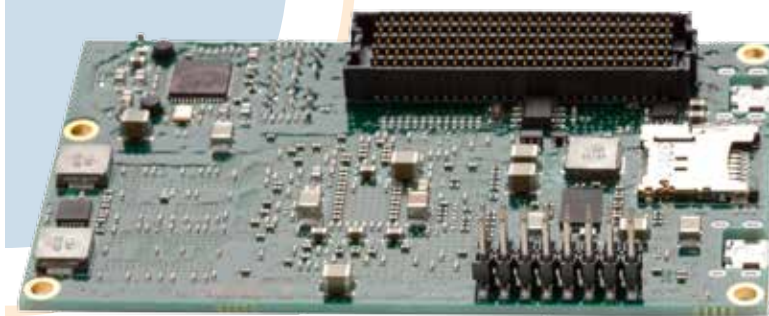

Actual Size - Top



Actual Size - Bottom

The EPT1020xS board is a compact, cost-effective, and powerful platform for developing high performance networked control platforms. At only 3.5" x 2.2" x 0.9", the board will fit into compact spaces, while 1 serial port (via USB), 1 USB port, and 1 Gigabit Ethernet port plus the EBC connector provide the necessary control I/O.

The External Bus Connector (EBC) provides direct access to the T1020 interfaces including SERDES, Ethernet and 1588. This high-speed compact interface will handle demanding applications.

At the heart of the EPT1020xS is the Freescale QorIQ T1020. The T1020 is a highly integrated SoC that includes multiple e5500 cores at speeds up to 1.4GHz, a floating point unit, flash controller, DDR3L RAM controller, USB 2.0 host and device controllers, and dual Gigabit Ethernet MACs. The high level of integration increases performance, while lowering system power consumption and cost.

The board is supported by the U-Boot bootloader and BSPs for Linux, VxWorks, and Green Hills INTEGRITY.

Feature Summary:

Specification:	Description:
Processor:	Freescale T1020 (or T1022, T1040 or T1042) at up to 1.4GHz
Memory:	RAM: Up to 1Gb DDR3L FLASH: Up to 256MB, with optional SD socket
EBC Connector:	Direct access to SERDES, Clocks, Ethernet, 1588, TSEC, USB, UARTs, GPIO, I2C, Flash and Power
Ethernet:	1 Gigabit port (Additional via EBC)
Serial Ports:	2 RS-232 (one on board and one on EBC)
USB:	2 USB 2.0 Host and Device (one on board and one on EBC)
I2C Devices:	EEPROM and Real Time Clock
Form Factor:	Fanless compact size 3.5" x 2.2" x 0.9" high
Debug:	On board JTAG debug connector

Hardware Block Diagram

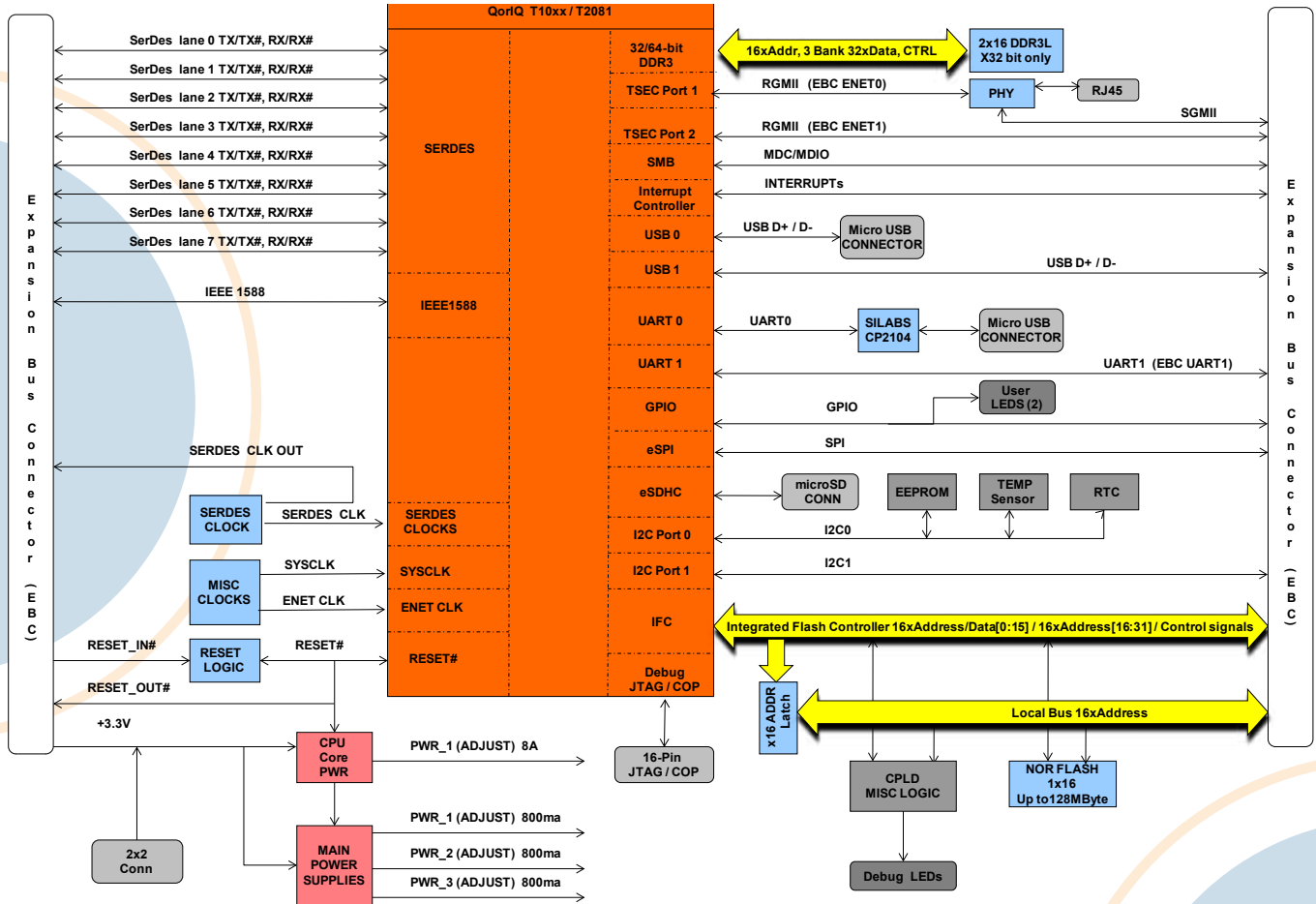

Let Us Do The Heavy Lifting

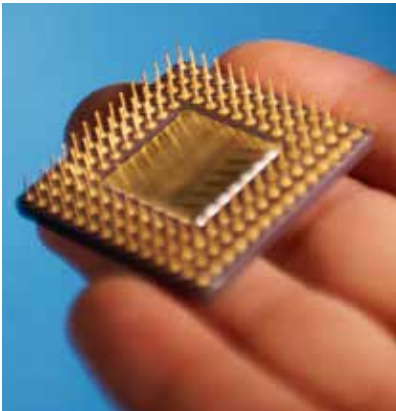

- Embedded Planet offers a complete set of software and hardware services to go along with our Off-the-Shelf solutions.
- Embedded Planet has extensive experience with embedded operating systems and firmware. Our stock configurations of operating systems and firmware can be customized to meet your particular needs.
- We can alleviate the headaches associated with volume production of embedded systems. Your product is delivered 100% tested from an ISO-9002 certified manufacturing facility.
- Our capabilities are available on a project basis to design custom solutions specifically tailored to your application.
- Contact Embedded Planet to find out how we can accelerate your project.

Copyright © 2013 Embedded Planet, Inc. All Rights Reserved.