



The EP8572A is a single width, full height AMC processor board featuring the high performance Freescale MPC8572 dual-core PowerPC processor operating at up to 1.5GHz. In addition to the AMC configuration the EP8572A can operate as a stand-alone module and boot from on board flash allowing for rapid application development outside of the integrated ATCA or MicroTCA environment. With broad operating support, the EP8572A is built for a broad range of demanding applications in wireless basestations, media gateways, enterprise network access systems, test and measurement systems, and server blades.

For fabric connectivity the both the EP8572A offers extreme flexibility, while maintaining standards compliance. All versions of the board support gigabit Ethernet on AMC channels 0 and 1, compliant with AMC.2, Type E2. Separate versions of the board are available in one of the following configurations: Serial RapidIO on AMC channels 4-7, PCI Express on AMC channels 4-11, or SCOPE-Compliant PCI Express on channels 4-7 and Serial RapidIO on channels 8-11.

At the heart of the EP8572A is a Freescale MPC8572 dual-core PowerPC processor. The MPC8572 is a highly integrated system-on-chip (SoC) platform that includes dual e500 PowerPC cores, an integrated security engine, integrated PCI Express, Serial RapidIO, and Gigabit Ethernet controllers, integrated DDR2/3 memory interface, and a pattern matching engine for packet inspection. The highly integrated SoC architecture improves system performance, simplifies board design, lowers power consumption, and reduces cost.

## Feature Summary:

Specification:	Description:
Form Factor:	Full or Mid-Height AMC.0
Backplane Options:	2 x GbE to AMC channels 0 and 1 with options for Serial RapidIO on channels 4-7, PCI Express on channels 4-11, or a combination of PCI Express on channels 4-7 and Serial RapidIO on channels 8-11
Front Panel:	2 x GbE connections and 1 x RS-232 serial
Processor:	Freescale Dual-Core MPC8572 at up to 1.5GHz
Memory:	Up to 8 GB DDR2 in two SODIMMS, up to 128 MB of NOR flash and 4GB of NAND flash
Debug:	JTAG/COP via an onboard connector
Power Supply:	Via AMC connector per AMC.0 or from barrel connector
Software:	U-Boot bootloader, Linux, INTEGRITY, and VxWorks BSP available

### Hardware Block Diagram

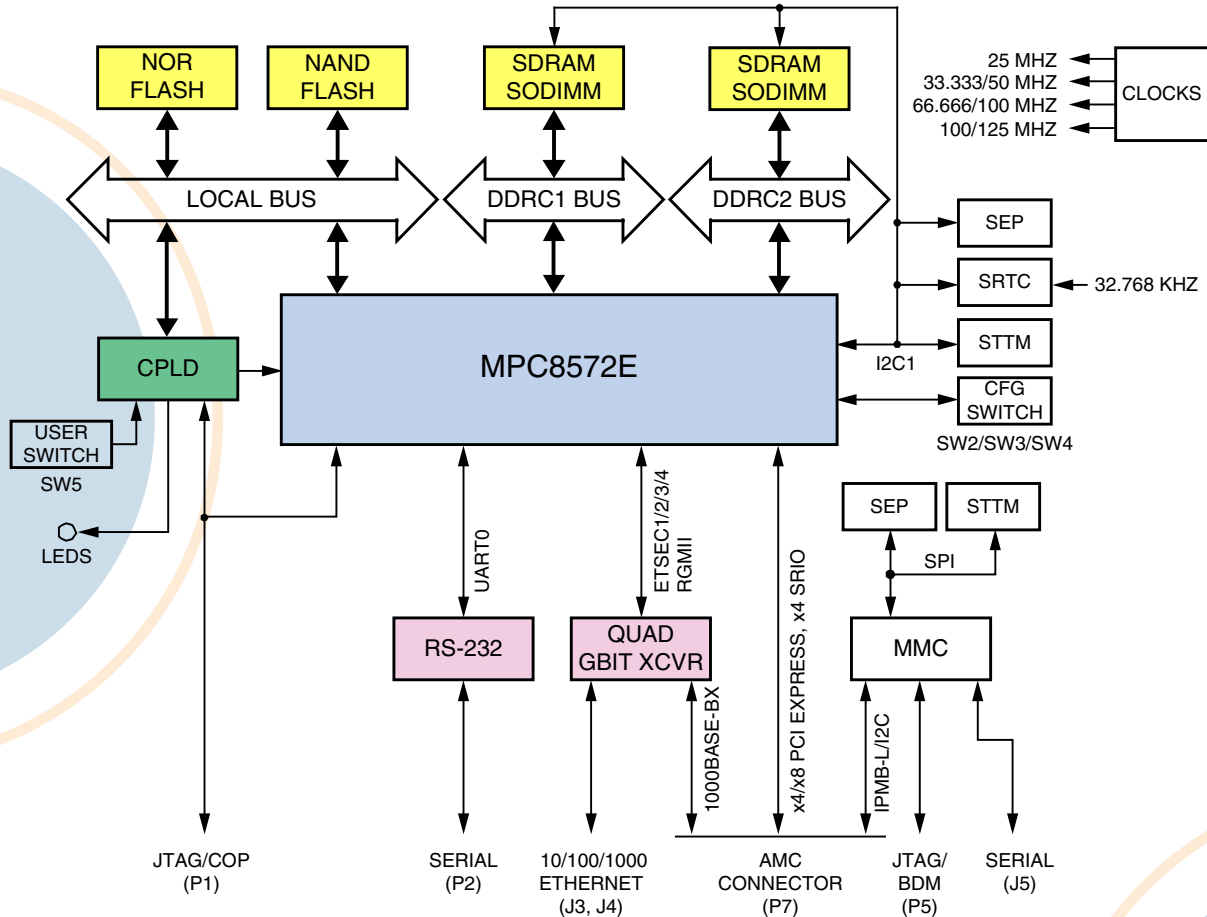

T00358A

## Let Us Do The Heavy Lifting

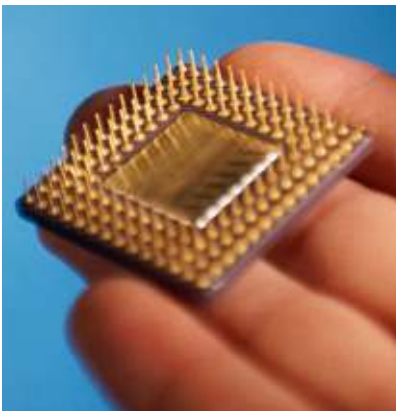

- Embedded Planet offers a complete set of software and hardware services to go along with our Off-the-Shelf solutions.
- Embedded Planet has extensive experience with embedded operating systems and firmware. Our stock configurations of operating systems and firmware can be customized to meet your particular needs.
- We can alleviate the headaches associated with volume production of embedded systems. Your product is delivered 100% tested from an ISO-9002 certified manufacturing facility.
- Our capabilities are available on a project basis to design custom solutions specifically tailored to your application.
- Contact Embedded Planet to find out how we can accelerate your project.