

The EPBBB-I is a industrial temp (-40° to +85°c) compact, cost-effective, and powerful platform for developing high performance applications including data acquisition, imaging, medical and industrial control. At only 3.4" x 2.1", the board will fit into compact spaces, while the USB port (via USB), and Ethernet port plus the EBC connector provide the necessary control I/O.

At the heart of the EPBBB-I is the Texas Instruments Sitara AM3358 processor with ARM Cortex A8 core. This processor is a highly integrated SoC with a core at speeds up to 1.0GHz, a flash controller, DDR3L RAM controller, USB 2.0 host and device controllers.

The high level of integration increases performance, while lowering system power consumption and cost.

The board stack is supported by the U-Boot bootloader and BSPs for Linux.

Feature Summary:

Specification:	Description:
Processor:	Texas Instruments Sitara AM3358 at 1GHz with Cortex-A8 Core
Memory:	RAM: 512MB DDR3L FLASH: 4GB 8 bit eMMC on board FLASH storage
Ethernet:	10/100
Serial Ports:	One UART on board, three on EBC
USB Client:	USB 2.0 Power and Communications
USB Host:	Applications
Graphics:	HDMI and 3D Accelerator
Operating Temp:	-40° to +85°c
Form Factor:	Fanless compact size
Software:	U-Boot Bootloader and Linux BSP available
Notes:	<i>We can customize this design for your specific application requirements.</i>

Order yours today at

Arrow.com

BB-BBLK-000-ITEMP

Hardware Block Diagram

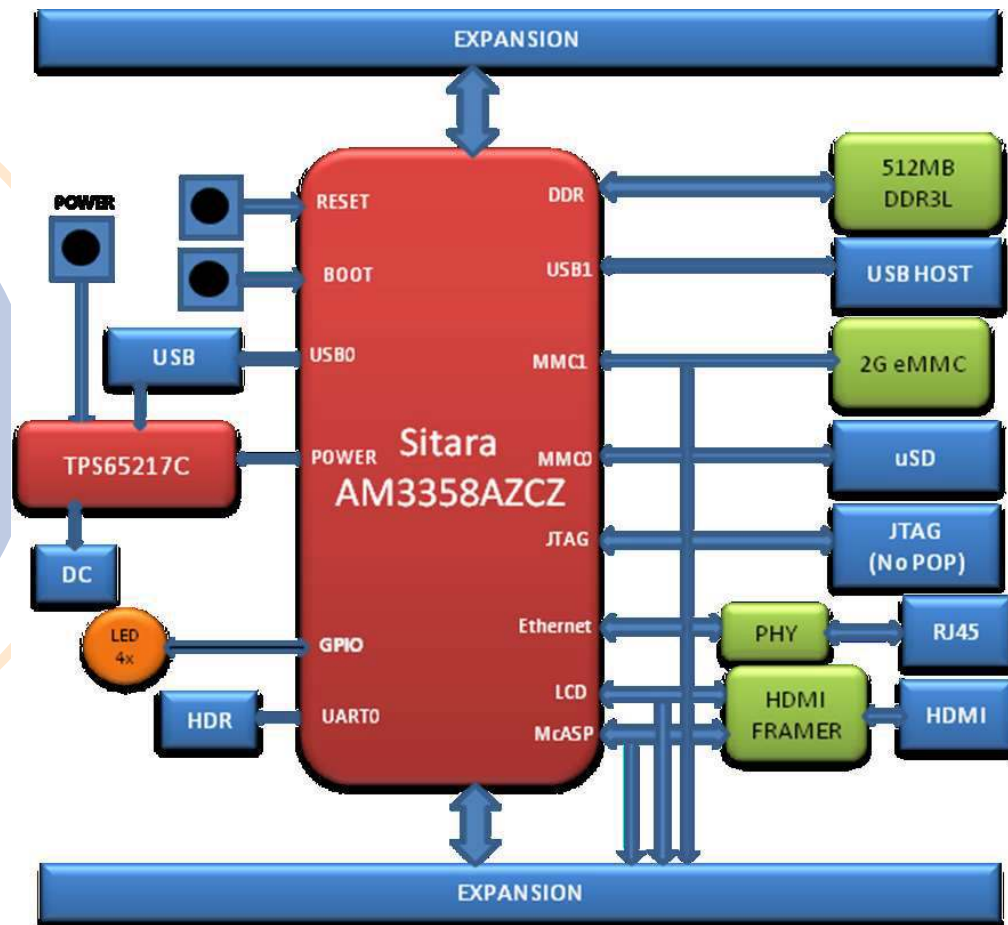

Let Us Do The Heavy Lifting



- Embedded Planet offers a complete set of software and hardware services to go along with our Off-the-Shelf solutions.
- Embedded Planet has extensive experience with embedded operating systems and firmware. Our stock configurations of operating systems and firmware can be customized to meet your particular needs.
- We can alleviate the headaches associated with volume production of embedded systems. Your product is delivered 100% tested from an ISO-9002 certified manufacturing facility.
- Our capabilities are available on a project basis to design custom solutions specifically tailored to your application.
- Contact Embedded Planet to find out how we can accelerate your project.