

# Agora53

LTE Cellular Modem + MCU, GNSS, Bluetooth, LoRa, & Sensors

## Product User Manual

Embedded Planet Inc. | v0.3 | 20 JAN 2026



## About This Manual

The **Agora53 User Manual** provides detailed information for the integration and use of Embedded Planet's Agora53 platform. For the latest documentation, including document & certification updates, please refer to the Embedded Planet documentation page: <https://www.embeddedplanet.com/product-documentation>

## Product Web Page

**Agora53:** <https://www.embeddedplanet.com/agora-53-embedded-modem/>

# Contents

- 1. Introduction .....4
- 2. Orderable Part Numbers.....5
- 3. Additional Resources .....5
- 4. Features .....6
  - 4.1. Wireless Modules .....6
  - 4.2. Antenna Connections .....6
  - 4.3. Connectors.....7
  - 4.4. Sensors .....8
  - 4.5. Mounting .....9
- 5. Block Diagram .....10
- 6. Device Specifications .....11
- 7. Modules.....12
  - 7.1. Modules | Bluetooth + MCU .....12
  - 7.2. Modules | LoRaWAN .....13
  - 7.3. Modules | Cellular + GNSS .....13
- 8. Sensors .....14
  - 8.1. Sensors | 6-Axis IMU .....14
  - 8.2. Sensors | Temp/Humidity/Pressure/Gas.....14
  - 8.3. Sensors | Temp/Humidity.....15
  - 8.4. Sensors | Time-of-Flight/ToF.....15
  - 8.5. Sensors | Microphone .....15
- 9. RGB LED .....16
- 10. Memory .....16
- 11. Power .....16
  - 11.1. Power | Battery Monitor .....16
  - 11.2. Power | Sensor Power Control.....17
  - 11.3. Power | Cell Module Power Control.....17
  - 11.4. Power | GNSS Power Control.....17
- 12. Development .....17
  - 12.1. Development | Programming & Flidor Development Board .....17
  - 12.2. Development | Programming & Debugging.....18
  - 12.3. Development | Hardware Integration .....19
- 13. Pinouts.....20
  - 13.1. MCU Pinout (BT40).....20
  - 13.2. Tectonic Edge™ Pinout .....23
  - 13.3. Modem Header Pinout .....26
- 14. Antennae .....27
  - 14.1. Antennae | Cellular Antenna .....27
  - 14.2. Antennae | GNSS Antenna.....28
  - 14.3. Antennae | LoRa Antenna .....28
- 15. Electrical Specifications.....29
  - 15.1. Absolute Maximum & Minimum Ratings.....29
  - 15.2. Recommended Operating Conditions.....29

<b>16. Mechanical Specifications</b> .....	<b>30</b>
<b>16.1. Physical Parameters</b> .....	<b>30</b>
<b>16.2. Environmental Specifications</b> .....	<b>31</b>
<b>17. Regulatory Information</b> .....	<b>31</b>
<b>17.1. Cellular Certifications &amp; Endorsements</b> .....	<b>31</b>
<b>17.2. RoHS Compliance</b> .....	<b>31</b>
<b>17.3. Interference Statement</b> .....	<b>31</b>
<b>17.4. FCC and ISED Compliance</b> .....	<b>32</b>
<b>17.5. Wireless Notice</b> .....	<b>32</b>
<b>17.6. External Antenna Requirements: LoRa</b> .....	<b>32</b>
<b>17.7. External Antenna Requirements: Cellular</b> .....	<b>32</b>
<b>17.8. End-Product Labeling Requirements</b> .....	<b>33</b>
<b>17.9. FCC Additional Testing, Part 15 Subpart B Disclaimer</b> .....	<b>33</b>
<b>18. Revision History</b> .....	<b>34</b>

# 1. Introduction

---

Agora53 is a wireless communications device with on-board sensors and processing.

Agora53 wireless capabilities include LTE Cat-M1 / Cat-NB cellular, LoRa and Bluetooth 5.4.

The available on-board sensors are a 6-axis IMU (accelerometer and gyroscope), an environmental sensor (temperature, humidity, ambient air pressure, air quality), a temperature and humidity sensor, a distance sensor (laser time-of-flight) and an audio sensor (microphone).

The on-board processing is provided by a Nordic Semiconductor nRF5340 which includes two ARM® Cortex®-M33 cores, a floating-point unit and a rich peripheral set. It has 1MB of program flash and 512kB of RAM to enable edge processing of sensor and other data. The state-of-the-art ARM® CryptoCell-312 provides hardware-accelerated cryptography, and together with the key management unit (KMU) peripheral, root-of-trust and secure key storage are implemented. The nRF5340 is [PSA Level 2 certified](#).

Agora53 is available as a standalone unit when combined with a lithium battery, enclosure and appropriate antennae. It is also available as a PCBA to be integrated into your own system, either with the standard 2x10 cell modem pin headers or via the Tectonic Edge™ board-edge connector.

Certifications include FCC, PTCRB, AT&T TRENDI, T-Mobile DICE (in process), and Verizon ODI (in process).

---

## 2. Orderable Part Numbers

---

EP Part Number	Bluetooth	Cellular	GNSS	LoRa	6-axis IMU	Environmental	Temp / Humidity	Distance	Audio
EP-AGR-5301-WW-01	•	•	•	•	•	•	•	•	•

## 3. Additional Resources

---

- Flidor Programmer & Debugger:  
<https://www.embeddedplanet.com/flidor>

## 4. Features

### 4.1. Wireless Modules

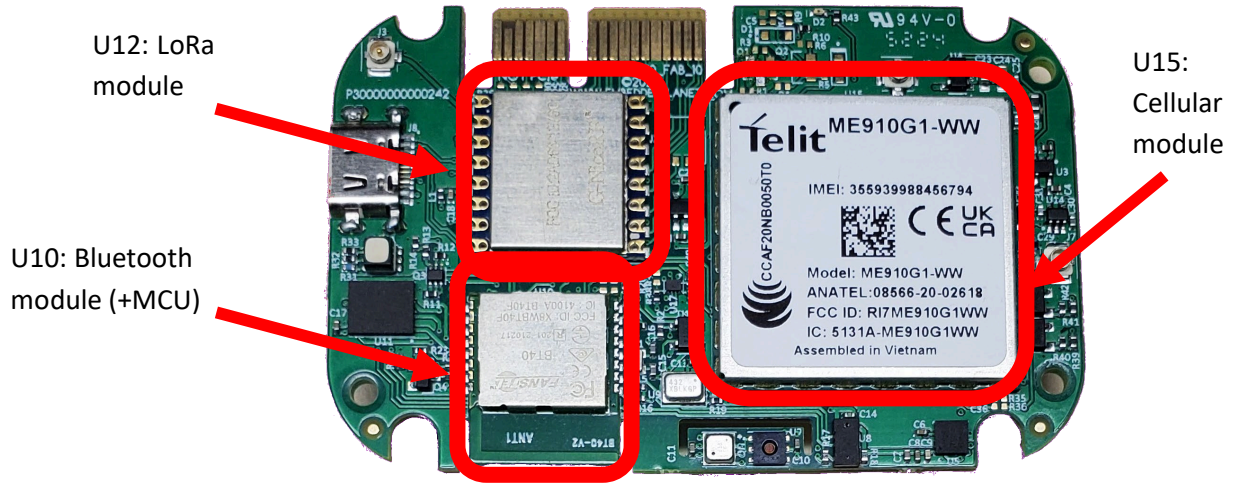

TABLE 1 – WIRELESS MODULES

Category	Reference	Functionality	Description / Purpose
Wireless Module	U10	Bluetooth transceiver	nRF5340 BLE + MCU module
Wireless Module	U12	LoRaWAN transceiver	LoRaWAN module (915MHz or 868MHz)
Wireless Module	U15	Cellular transceiver	Telit ME910G1-WW cellular + GNSS module

### 4.2. Antenna Connections

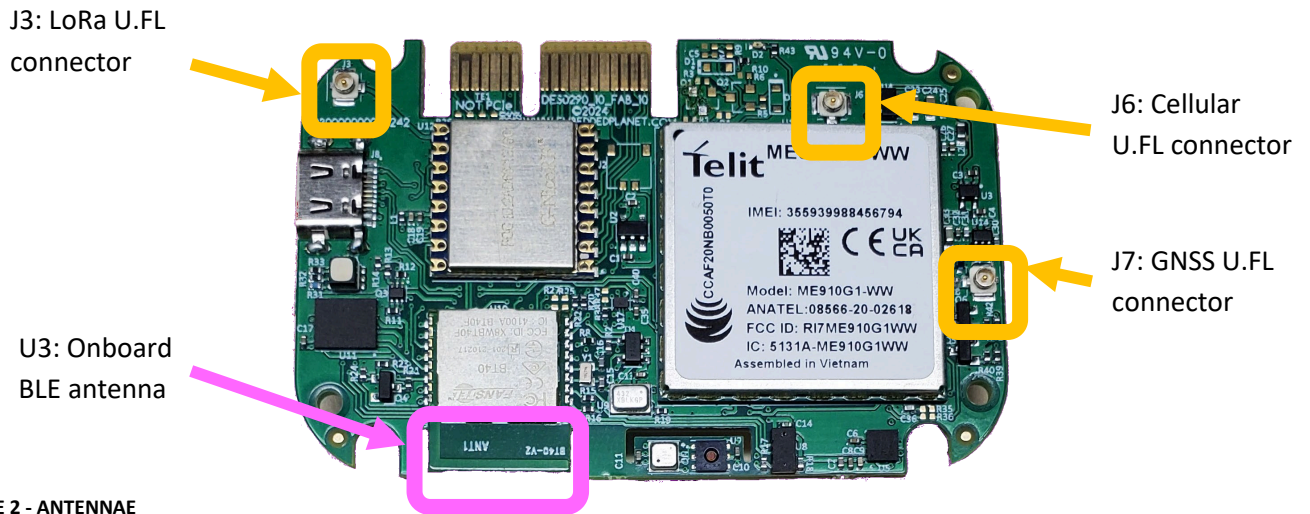

TABLE 2 - ANTENNAE

Category	Reference	Functionality	Description / Purpose
Antenna	U3	Bluetooth antenna	Onboard, no offboard connections
Connector	J3	LoRa U.FL connector	Offboard antenna supported
Connector	J6	Cellular U.FL connector	Offboard antenna supported
Connector	J7	GNSS U.FL connector	Offboard antenna supported

### 4.3. Connectors

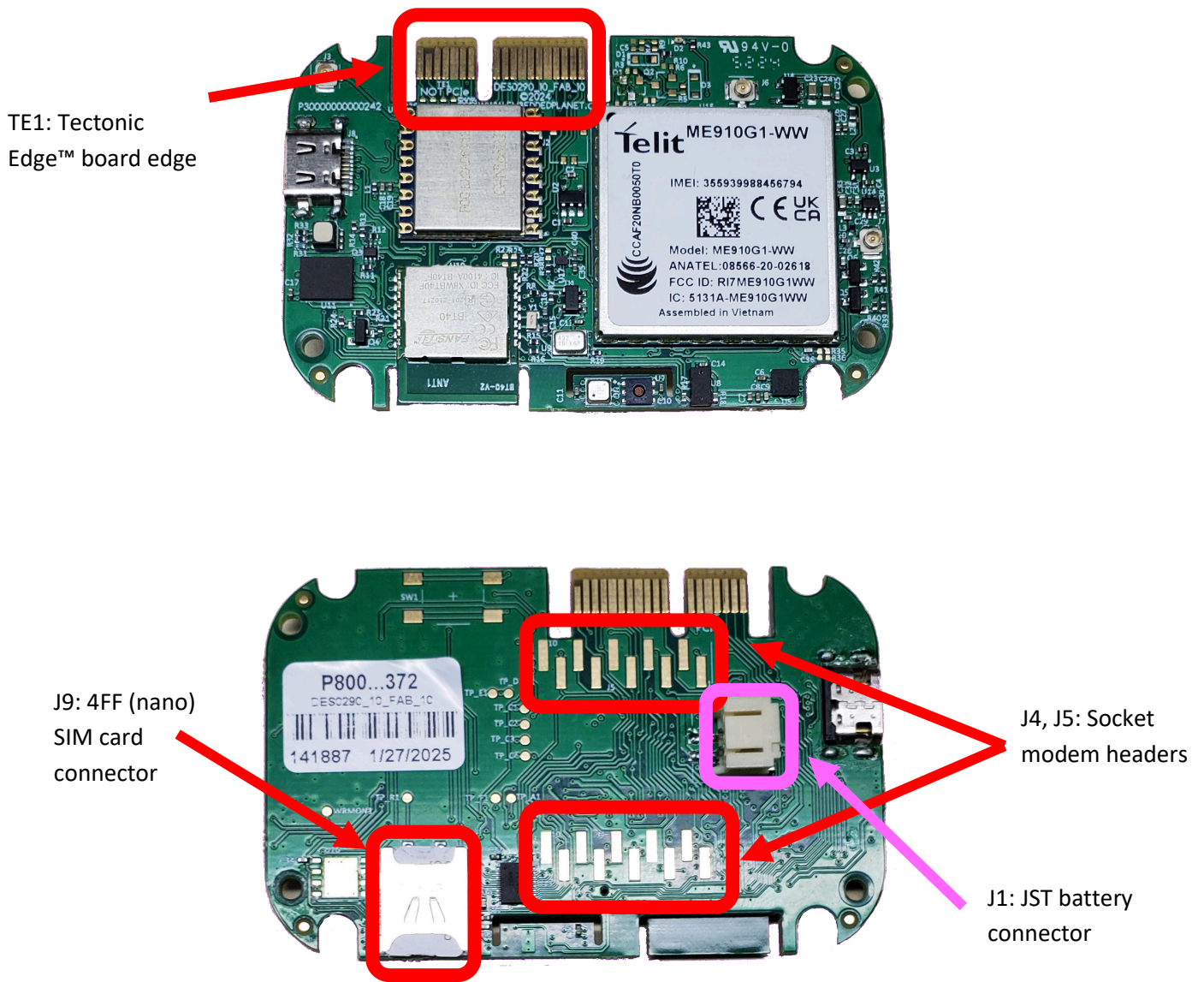

TABLE 3 – CONNECTORS

Category	Reference	Functionality	Description / Purpose
Connector	J1	JST battery connector	Optional JST battery connection
Connector	J4, J5	Socket modem pin headers	Drop-in 20-pin header modem applications
Connector	J9	4FF (nano) SIM card connector	SIM card interface
Board Interface	TE1	Board edge/finger	Tectonic Edge™ programming & debug

## 4.4. Sensors

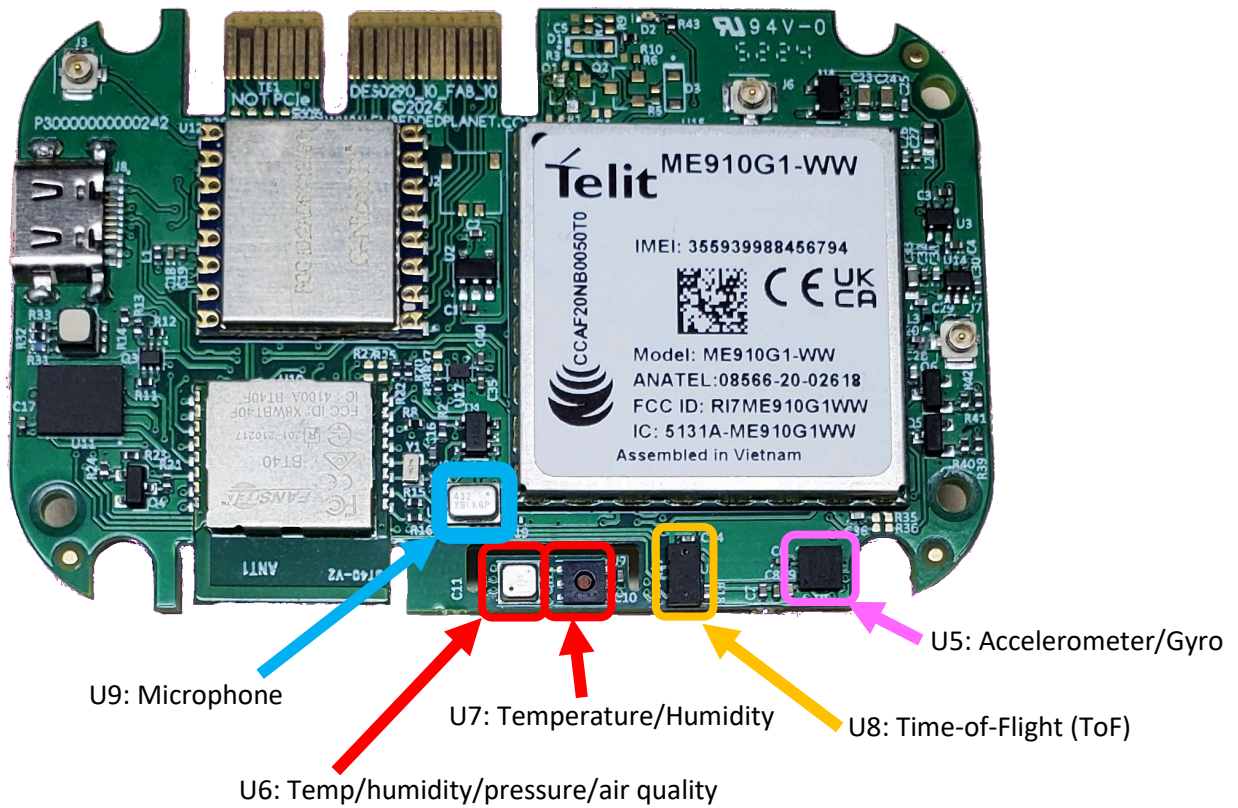

TABLE 4 – SENSORS

Category	Reference	Functionality	Description / Purpose
Sensor	U5	Accelerometer/Gyroscope	ICM-20602   Inertial sensor
Sensor	U6	Temperature/Humidity/Pressure/Air Quality	BME680   Environmental sensor
Sensor	U7	Temperature/Humidity	Si7021-A20   Environmental sensor
Sensor	U8	Time-of-Flight (ToF)	VL53L0X   Distance sensor
Sensor	U9	Microphone	ICS-43432   Audio sensor

## 4.5. Mounting

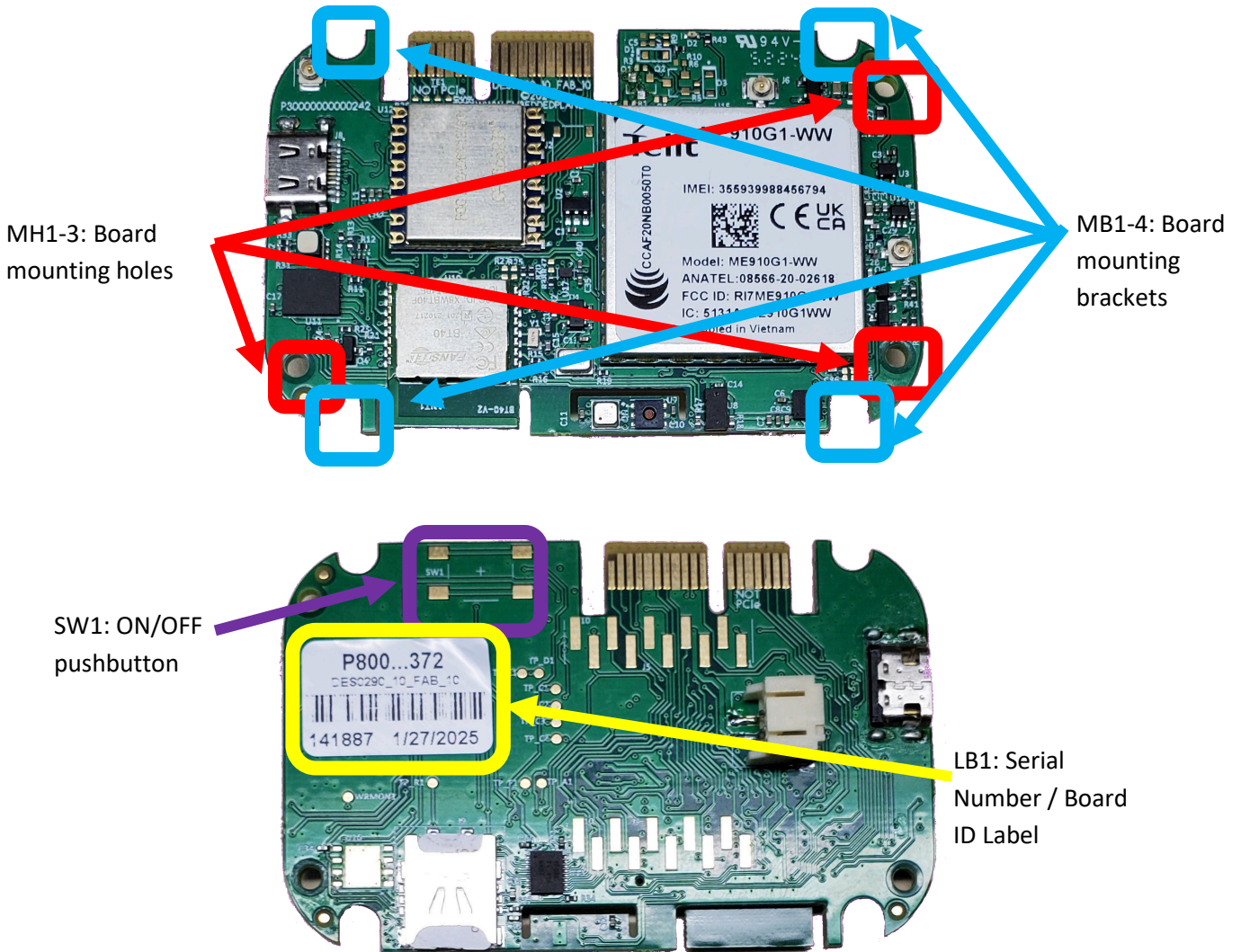
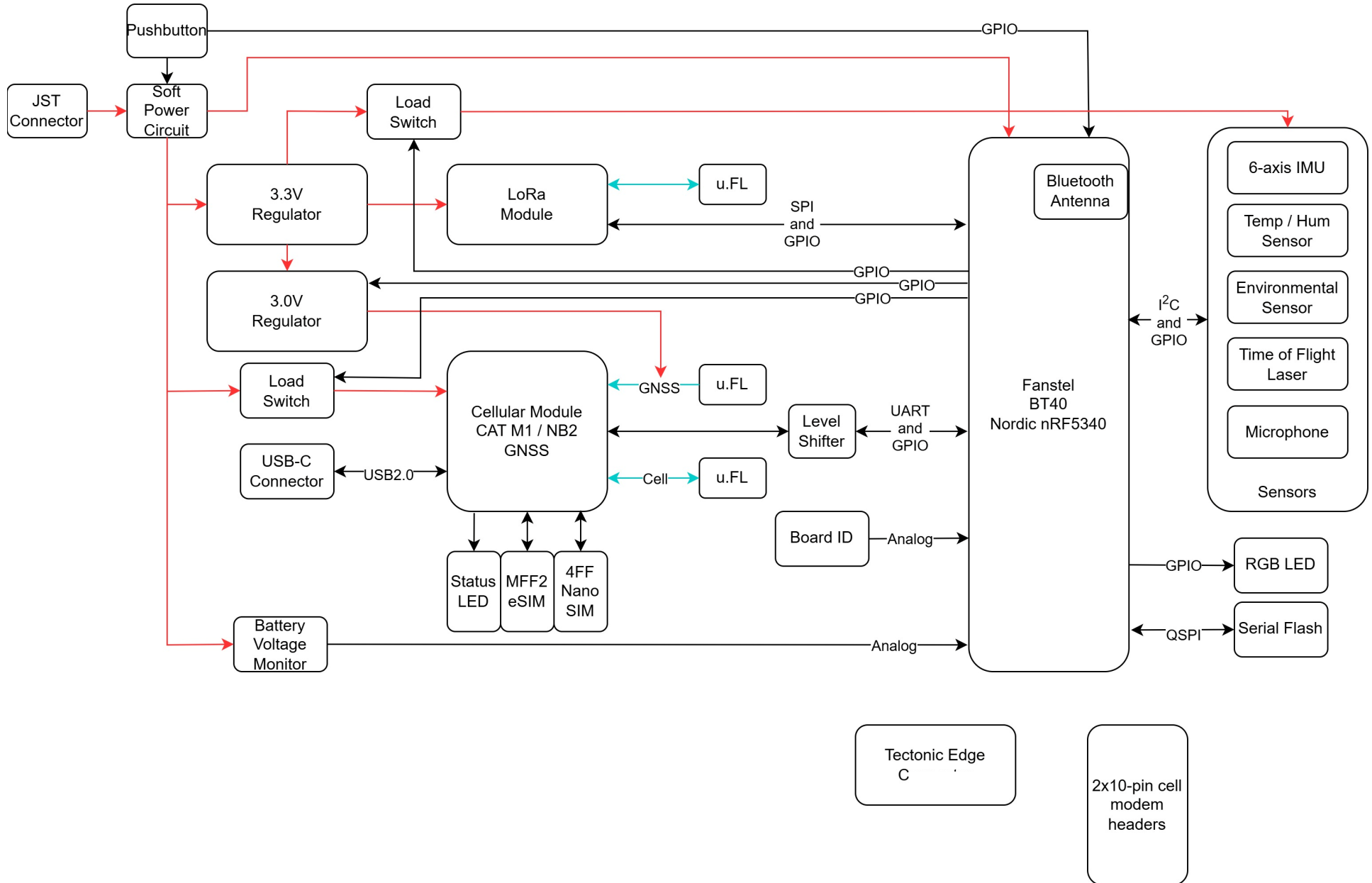

TABLE 5 – MOUNTING & INTERACTION

Category	Reference	Functionality	Description / Purpose
Mounting	MB1-4	Mounting bracket	For use with the Agora plastic housing
Mounting	MH1-4	Mounting hole	For mounting the Agora
Pushbutton	SW1	ON/OFF switch to the board	Soft power button to the Agora
Label	LB1	Board ID Label	Identification & serialization reference

## 5. Block Diagram



## 6. Device Specifications

TABLE 6 – DEVICE SPECIFICATIONS

Agora53 Feature	Description
<b>Cellular</b>	<p><b>Cellular Technologies:</b> 3GPP Release 14 (LTE Cat-M1/Cat-NB) with 2G fallback</p> <p><b>RF Output Power:</b> LTE: +23dBm (Power Class 3), GSM/GPRS: +33dBm (Power Class 4)</p> <p><b>Low power modes:</b> PSM, eDRX</p> <p><b>Cellular Operating Mode:</b> Half-duplex FDD</p> <p><b>Antenna:</b> Single antenna</p>
<b>Internet Protocols</b>	<p>IPv4/IPv6 stack with TCP and UDP protocols</p> <p>TLS 1.3 /DTLS</p>
<b>LTE CAT-M1</b>	<p><b>Bands (4G):</b> B1, B2, B3, B4, B5, B8, B12, B13, B18, B19, B20, B25, B26, B27, B28, B66, B71, B85</p> <p><b>Bands (2G):</b> B2, B3, B5, B8</p> <p><b>Uplink:</b> Cat M1: up to 1Mbps, Cat NB2: up to 160kbps</p> <p><b>Downlink:</b> Cat M1: up to 588kbps, Cat NB2: up to 120kbps</p>
<b>SIM</b>	<p><b>Removable:</b> 4FF (nano) SIM card slot</p> <p><b>Board-mounted:</b> MFF2 eSIM</p>
<b>Cellular Certification</b>	<p><b>PTCRB:</b> <a href="https://iotnetworkcertified.com/certified-device-details/?model=60477">https://iotnetworkcertified.com/certified-device-details/?model=60477</a></p> <p><b>AT&amp;T TRENDI:</b> <a href="https://c2m-projectone.att.com/PartnerCatalog/iotcertifieddevicedetail.aspx?cid=NDE5&amp;type=1&amp;skey=ZW1iZWRkZlWQgcGxhbmV0&amp;orderBy=1&amp;q=">https://c2m-projectone.att.com/PartnerCatalog/iotcertifieddevicedetail.aspx?cid=NDE5&amp;type=1&amp;skey=ZW1iZWRkZlWQgcGxhbmV0&amp;orderBy=1&amp;q=</a></p> <p><b>T-Mobile DICE:</b> in process</p> <p><b>Verizon ODI:</b> In process</p>
<b>GNSS Specification</b>	<p><b>Constellations:</b> GPS, GLONASS, BeiDou, Galileo</p> <p><b>Tracking Sensitivity:</b> -159dBm</p> <p><b>Navigation Sensitivity:</b> -155dBm</p> <p><b>Cold Start Sensitivity:</b> -144Bm</p>
<b>Input Voltage</b>	<p><b>Nominal Voltage:</b> 3.8Vdc</p> <p><b>Voltage Range:</b> 3.2-4.2Vdc</p>
<b>Dimensions</b>	<p><b>Board-only, fully populated:</b> 70 mm x 45 mm x 16.3 mm (2.75 in x 1.77 in x 0.64in)</p>
<b>Environment</b>	<p><b>Operating Temperature Range (PCBA only):</b> -40°C to +85°C</p> <p><b>Storage Temperature Range (PCBA only):</b> -40°C to +85°C</p> <p><b>Humidity Range:</b> 20% RH to 90% RH</p>

## 7. Modules

---

### 7.1. Modules | Bluetooth + MCU

---

The MCU on Agora53 is Nordic Semiconductor's nRF5340, supplied in Fanstel's BT40 module. The BT40 is a certified module that contains the nRF5340 along with all the required supporting hardware and an integrated Bluetooth PCB antenna.

Features of the Fanstel BT40 include dual 32-bit cores.

The network core is a 64MHz Arm® Cortex®-M33 with 256kB of program flash and 64kB of RAM, optimized for low power. The network core is provided to control the module's radio and supports Bluetooth LE, Bluetooth mesh, Thread, Zigbee, Matter, ANT and NFC.

The application core is a 128/64MHz Arm® Cortex®-M33 with 1MB of program flash and 512kB of RAM, optimized for performance. A floating-point unit with an 8kB 2-way associative cache provides DSP instruction capabilities.

A rich set of peripherals enables a wide variety of applications

The module offers a high level of security with trusted execution, root-of-trust and secure key storage. ARM® TrustZone® provides trusted execution by implementing a division between secure and non-secure Flash, RAM, peripherals and GPIOs. The state-of-the-art ARM® CryptoCell®-312 provides hardware-accelerated cryptography, and together with the key management unit (KMU) peripheral, root-of-trust and secure key storage are implemented. The nRF5340 is [PSA Level 2 certified](#).

Agora53 supports the development of code for the nRF5340 MCU via the Tectonic Edge™ board edge connection system used throughout Embedded Planet products.

Flidor, a programming & debug host board with Tectonic Edge™ compatibility, is the preferred development tool for use with Agora53. Flidor provides convenient access to many of Agora53's features. The Agora53 Development Kit includes Flidor and is strongly recommended for users who want to develop on Agora53.

More on Flidor can be found at <https://www.embeddedplanet.com/product-documentation/#flidor>

Further details on the nRF5340 can be found here:  
<https://www.nordicsemi.com/Products/nRF5340>

Further details on the Fanstel BT40 module can be found here:  
<https://www.fanstel.com/bt40f-nrf5340>

## 7.2. Modules | LoRaWAN

---

LoRaWAN is supported on Agora2.0 by the NiceRF LoRa1276-C1-915 module. This module contains a Semtech SX1276 transceiver. A u.FL connector is supplied for use with an external antenna.

Agora53's MCU communicates with the LoRa module using SPI and several GPIO.

For more information on the NiceRF LoRa1276-C1-915 (915MHz) module, please see:

<https://www.nicerf.com/products/detail/lora-wireless-transceiver-module-lora1276-c1-915.html>

## 7.3. Modules | Cellular + GNSS

---

Agora53 includes the Telit ME910G1-WW cellular module. This cellular module supports 3GPP Rel.14 LTE Cat M1 and LT Cat NB along with 2G (GSM/GPRS) fallback. The ME910G1-WW also supports several GNSS constellations – GPS, GLONASS, Beidou and Galileo).

Agora53's MCU communicates with the cellular module using UART and several GPIO.

Compliant with 3GPP Rel.14, the module enables increased power saving for IoT applications using Power Saving Mode (PSM) and extended Discontinuous Reception (eDRX). These features allow Agora2.0 to wake up periodically and deliver only small amounts of data necessary before returning to sleep mode. Enhanced coverage, enabled by maximum coupling loss (MCL) of up to +15 dB/+20 dB, provides superior in-building penetration compared to earlier cellular LTE standards.

More information on the Telit ME910 series modules can be found at:

<https://www.telit.com/devices/me910g1-series/>

u.FL connectors are included for external cellular and active GNSS antennae. See the Antennae section later in this document for antenna requirements and recommendations.

## 8. Sensors

---

Agora53 supports up to five on-board sensors.

### 8.1. Sensors | 6-Axis IMU

---

Agora53 supports the InvenSense ICM-20602 6-axis IMU sensor. This sensor is comprised of a 3-axis accelerometer and a 3-axis gyroscope. Features of this sensor include:

- Integrated 16-bit ADC
- Programmable digital filters
- Embedded temperature sensor
- Programmable interrupts
- 3-axis gyroscope
  - Programmable ranges of  $\pm 250\text{dps}$ ,  $\pm 500\text{dps}$ ,  $\pm 1000\text{dps}$  and  $\pm 2000\text{dps}$
  - Sensitivity error:  $\pm 1\%$
  - Noise:  $\pm 4\text{mdps}/\sqrt{\text{Hz}}$
- 3-axis accelerometer
  - Programmable ranges of  $\pm 2\text{g}$ ,  $\pm 4\text{g}$ ,  $\pm 8\text{g}$ ,  $\pm 16\text{g}$
  - Sensitivity error  $\pm 1\%$
  - Noise:  $100\mu\text{g}/\sqrt{\text{Hz}}$

This sensor communicates with the nRF340 MCU over I<sup>2</sup>C using the address (**1101000b, 0x68**).

For more information on the InvenSense ICM-20602, please see:

<https://invensense.tdk.com/products/motion-tracking/6-axis/icm-20602/>

### 8.2. Sensors | Temp/Humidity/Pressure/Gas

---

Agora53 supports the Bosch BME680 environmental sensor. This sensor has the ability to measure temperature, humidity, barometric pressure, and VOC gas. Features of this sensor include:

- Temperature sensor:  $\pm 1^\circ\text{C}$  temperature accuracy ( $0^\circ\text{C}$  to  $+65^\circ\text{C}$ ), up to 20-bit resolution
- Humidity sensor:  $\pm 3\%$  relative humidity accuracy (20-80% RH), 16-bit resolution
- Pressure sensor:  $\pm 0.6\text{hPa}$  pressure accuracy (300-1000hPa), up to 20-bit resolution
- VOC gas sensor:
  - Ethane: 5% accuracy
  - Isoprene / 2-methyl-1,3 Butadiene: 5% accuracy
  - Ethanol: 5% accuracy
  - Acetone: 5% accuracy
  - Carbon Monoxide: 2% accuracy

This sensor communicates with the nRF5340 MCU over I<sup>2</sup>C using the address **1110110b (0x76)**.

For more information on the Bosch BME680 please see:

<https://www.bosch-sensortec.com/products/environmental-sensors/gas-sensors/bme680/>

## 8.3. Sensors | Temp/Humidity

---

Agora53 supports the Silicon Labs Si7021-A20 temperature & humidity sensor. Features of this sensor include:

- Integrated ADC: up to 14-bit for temperature and up to 12-bit for humidity
- $\pm 0.4^{\circ}\text{C}$  temperature accuracy ( $-10^{\circ}\text{C}$  to  $+85^{\circ}\text{C}$ )
- $\pm 3\%$  relative humidity accuracy (0-80% RH)

This sensor communicates with the nRF5340 MCU over I<sup>2</sup>C using the address **1000000b (056x40)**.

For more information on the Silicon Labs Si7021-A20, please see:

<https://www.silabs.com/sensors/humidity/si7006-13-20-21-34/device.si7021-a20-gm>

## 8.4. Sensors | Time-of-Flight/ToF

---

Agora53 supports the ST VL53L0X time of flight (ToF) sensor. Features of this sensor include:

- Distances measurement up to 2 meters
- Ability to provide distance measurements despite target reflectance
- White target max range: minimum 120cm indoor (4% accuracy), 60cm outdoor overcast (7% accuracy)
- Grey target max range: minimum 70cm indoor (7% accuracy), 40cm outdoor overcast (12% accuracy)
- SPAD array (Single Photon Avalanche Diodes) with embedded FlightSense technology
- Laser invisible to the human eye

This sensor communicates with the nRF5340 MCU over I<sup>2</sup>C using the address **0101001b (0x29)**.

For more information on the ST VL53L0X, please see:

<https://www.st.com/en/imaging-and-photonics-solutions/vl53l0x.html>

## 8.5. Sensors | Microphone

---

Agora53 supports the InvenSense ICS-43432 low-noise microphone. Features of this sensor include:

- High 65 dBA SNR
- $-26$  dB FS Sensitivity
- $\pm 1$  dB Sensitivity Tolerance
- Wide Frequency Response from 50 Hz to 20 kHz
- Low Current Consumption: 1.0 mA
- High Power Supply Rejection:  $-80$  dB FS
- 116 dB SPL Acoustic Overload Point

This sensor communicates with the nRF5340 MCU over I<sup>2</sup>S.

For more information on the InvenSense ICS-43432, please see:

<https://invensense.tdk.com/products/digital/ics-43432/>

## 9. RGB LED

---

Agora53 includes an RGB LED which is under the control of three GPIO from the nRF5340.

## 10. Memory

---

Agora53 supports on-board NOR flash. The flash is connected to the MCU over QPSI and can be used to perform XIP. The nRF5340 supports an XIP memory space of 256Mb (32MB).

The flash module used in the default Agora53 configuration is the 32Mb NOR flash W25Q32JVZPIQ by Winbond. The 6mm x 5mm WSON8 package supports flash densities up to 256Mb – please contact Embedded Planet if your application requires more than 32Mb of QSPI NOR flash.

For more information on the Winbond W25Q32JV series, please see:

[https://www.winbond.com/hq/product/code-storage-flash-memory/serial-nor-flash/?\\_locale=en&partNo=W25Q32JV](https://www.winbond.com/hq/product/code-storage-flash-memory/serial-nor-flash/?_locale=en&partNo=W25Q32JV)

## 11. Power

---

Agora53 is powered through VBAT, nominally 3.8V with a range of 3.2V to 4.2V.

VBAT appears on Tectonic Edge™ pin A13 and on the 2x10-pin headers J4, pin 1. This allows Agora2.0 to be directly powered from a carrier board.

VBAT is also the output of the soft power switch circuit which takes its input from a JST S2B-PH-SM4-TB connector. This allows Agora53 to be powered from a battery, typically a 1SxP lithium battery.

Pressing SW1 toggles the state of the soft power circuit.

### 11.1. Power | Battery Monitor

---

Agora53 includes a battery voltage monitor. The battery voltage monitor is controlled by a GPIO from the MCU and is normally off so that it does not place any load on the battery. When turned on, the battery voltage monitor presents one-half of the battery voltage to an ADC input pin on the MCU.

Since the battery voltage may be as high as 4.2V, this means that up to 2.1V will be presented to the ADC pin. The ADC reference for this input must be set to at least 2.4V to accommodate the battery voltage monitor output.

The circuit is high impedance minimizing the drain on the battery when the circuit is on. For accurate readings, the ADC channel must be set to the maximum acquisition time of 40µs.

Refer to the MCU pinout below for details on the pins used.

## 11.2. Power | Sensor Power Control

---

Power to all the onboard sensors is controlled by the MCU via a load switch. The load switch takes the regulated 3.3V rail as its input and is normally off. The MCU control pin must be set high to turn on the load switch and power the sensors.

Refer to the MCU pinout below for details on the pins used.

## 11.3. Power | Cell Module Power Control

---

Power to the cell module is controlled by the MCU via a load switch. The load switch takes VBAT as its input and is normally off. The MCU control pin must be set high to turn on the load switch and power the cell module.

Refer to the MCU pinout below for details on the pins used.

## 11.4. Power | GNSS Power Control

---

Power to the active GNSS antenna is controlled by the MCU via a 3.0V regulator. The regulator takes the regulated 3.3V rail as its input and is normally off. The MCU control pin must be set high to turn on the load switch and power the active GNSS antenna.

Refer to the MCU pinout below for details on the pins used.

## 12. Development

---

Agora53 is designed to support the deployment of standard hardware/software configurations as well as the development of custom hardware or software solutions. Whether Agora is being used as an integrated component within an end product or being used for development to clear the way for a custom integration solution, hardware and software development are essential parts of Agora's time-to-market solution success.

### 12.1. Development | Programming & Flidor Development Board

---

Development on Agora53 is supported by the Flidor programming & debugging board. This host board connects to Agora53 using the Tectonic Edge™ interface and acts as a programming interface, a debug interface, and hardware breakout. Power can be supplied through USB-microB, barrel jacks, or JST LiPo battery connector.

Programming through Flidor is done using ARM Cortex debug headers.

Flidor also provides breakout lines of power lines, GPIO, and signal lines (UART, I<sup>2</sup>C, QSPI, and more). Current measurements can be accommodated through Flidor using optional pin headers and/or cut traces.

A Flidor board is included in the Agora53 Development Kit. For more information on Flidor, please visit <https://www.embeddedplanet.com/product-documentation/#flidor>.



## 12.2. Development | Programming & Debugging

Agora53 supports a diverse range of firmware applications. Sample applications are provided by Embedded Planet as github resources and referenced in Quick Start Guides.

To view available Quick Start Guides and other supporting documentation, please refer to: <https://www.embeddedplanet.com/product-documentation>

To directly access available sample application and other github documentation, please refer to: <https://github.com/orgs/EmbeddedPlanet/repositories>

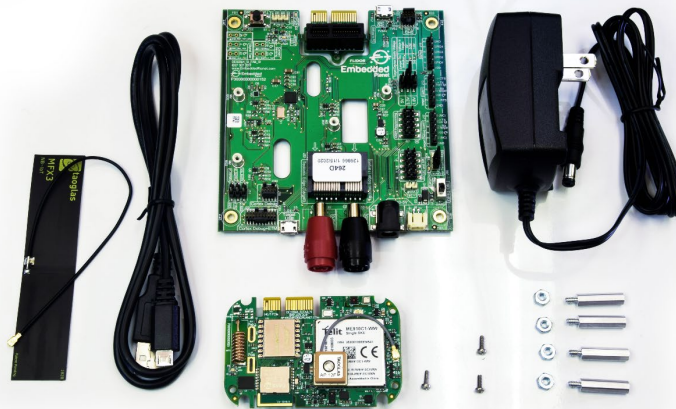

*Shown above: Agora Development Kit including Agora PCBA and Flidor board*

- 1.

## 12.3. Development | Hardware Integration

---

Agora53 can be integrated into new hardware designs as well as existing ones. The recommended interface for Agora's hardware integration is the Tectonic Edge™ connection system. This manual specifies detail on the pinout, connectors, and more in the Tectonic Edge™ section. Additional documentation, including Tectonic Edge™ PCB footprint integration & modem header integration, is available at <https://www.embeddedplanet.com/product-documentation>.

## 13. Pinouts

### 13.1. MCU Pinout (BT40)

**TABLE 7 – MCU PINOUT (BT40)**

Pin	BT40 (nRF53)	Connection on Agora53	Type	Direction	TechEdge	Notes
1	P1.02	SDA	Digital	I/O	B7	
2	P1.03	SCL	Digital	Output	B6	
3	nc	nc	nc			BT40 has internal 32.768kHz oscillator
4	nc	nc	nc			BT40 has internal 32.768kHz oscillator
5	P0.04/AIN0	Battery monitor analog	Analog	Input		
6	P0.05/AIN1	Board ID analog input	Analog	Input		
7	P0.02/NFC1	J3 - NFC antenna	RF			
8	P0.03/NFC2	J3 - NFC antenna	RF			
9	VDD	VDD_nRF	Power	Output	A12	Vref on TecEdge - to be used as I/O reference only, not power supply
10	VSS	COM	Power		B5	
11	P0.09/MOSI	LoRa_MOSI	Digital	Output	B2	
12	P0.11	SWO	Digital	Output	A18	
13	P0.30	DEBUG_TX	Digital	Output	B12	
14	/RESET	RESET	Digital	Input	A17	
15	SWDCLK	SWDCLK	Digital	Input	A16	
16	SWDIO	SWDIO	Digital	I/O	A15	
Z0	P1.09	CELL_RTS	Digital	Output	A2	
Z1	P1.10	CELL_TX	Digital	Output	A1	
Z2	P1.11	TE_GPIO7	Digital	I/O	B16	Populate R29 to connect to LoRa_DIO2; populate R25 to connect to CELL_DSR
Z3	P1.12	TE_GPIO8	Digital	I/O	B17	Populate R30 to connect to LoRa_DIO3; populate R27 to connect to CELL_DTR
Z4	P1.13	CELL_PWRMON	Digital	I/O		
Z5	P1.14	LoRa_RESET#	Digital	Output		
Z6	P1.15	Board ID EN#	Digital	Output		
A0	VSS	COM	Power		B8	
A1	P0.06/AIN2	INT_TOF	Digital	Input		
A2	P0.07/AIN3	PB	Digital	Input		

Pin	BT40 (nRF53)	Connection on Agora53	Type	Direction	TechEdge	Notes
A3	P0.08/SCK	CELL_PWR_EN	Digital	Output		
A4	P0.16/SPIIO3	QSPI_IO3	Digital	I/O		
A5	P1.00	LoRa_SCLK	Digital	Output	B3	
A6	P1.08	CELL_CTS	Digital	Input	A4	
B0	VSS	COM	Power			
B1	P0.19	I2S_SD	Digital	Input	B11	
B2	P0.17/SCK	QSPI_CLK	Digital	Output		
B3	P0.14/SPIIO1	QSPI_IO1	Digital	I/O		
B4	P0.15/SPIIO2	QSPI_IO2	Digital	I/O		
B5	P0.12/DCX	IS2_WS	Digital	Output	A6	
B6	P0.13/SPIIO0	QSPI_IO0	Digital	I/O		
C0	VSS	COM	Power			
C1	P0.31	CELL_HW_SHUTDOWN	Digital	Output		
C2	P0.21	LED_RED	Digital	Output		
C3	P0.24	I2S_SCK	Digital	Output	A7	
C4	P0.23	TE_GPIO9	Digital	I/O	B18	Populate R26 to connect to CELL_DCD
C5	P0.20	TE_GPIO6	Digital	I/O	B15	Populate R28 to connect to LoRa_DIO1
C6	P0.25/AIN4	LoRa_SS#	Digital	Output	B4	
D0	VSS	COM	Power			
D1	P0.26/AIN5	LED_GRN	Digital	Output		
D2	P0.27/AIN6	CELL_ON_OFF	Digital	Output	B9	
D3	P0.28/AIN7	DEBUG_RX	Digital	Input	B13	
D4	P0.29	BAT_MON_EN	Digital	Output		
D5	P0.22	CELL_RX	Digital	Input	A3	
D6	P1.01	INT_ACCEL	Digital	Input		
E0	P1.04	LoRa_DIO0	Digital	I/O		
E1	P1.05	SENSOR_PWR_EN	Digital	Output	B10	
E2	P1.06	LED_BLU	Digital	Output		
E3	P1.07	QSPI_CS#				DO NOT USE – tied to P0.18/CSN which is the QSPI_CS# for the nRF53
E4	D+	USB	USB	I/O	A9	
E5	D-	USB	USB	I/O	A10	
E6	P0.10/MISO	LoRa_MISO	Digital	Input	B1	

Pin	BT40 (nRF53)	Connection on Agora53	Type	Direction	TechEdge	Notes
F0/H0		COM	Power		B14	
F1/H1		COM	Power		A5	
F2/H2		COM	Power		A8	
F3/H3		COM	Power		A14	
F3	P0.18/CSN	QSPI_CS#	None	None		This is the QSPI_CS# for the nRF53
F4	VDDH	VBAT	Power	Input	A13	Input power
F5	NC	nc	Power			
F6	VBUS	USB	USB	Input	A11	

## 13.2. Tectonic Edge™ Pinout

Agora53 uses the Tectonic Edge™ connector to power, program, and debug the board as well as break out various data lines. Tectonic Edge™ mates with a standard PCIe (PCI-express) connector. Recommended connectors for use with Agora53 are Samtec PCIE-036-02-F-D-RA (right-angle) or Amphenol 10018784-10000TLF (vertical). See the Hardware Integration section of this manual for more detail on integrating Agora53 into another design using the Tectonic Edge™ interface. Additional footprint and hardware integration details are available at <https://www.embeddedplanet.com/product-documentation>.



In the following diagrams, the red image (first) represents the top side of the Agora53 board, and the blue image (second) represents the bottom side of the Agora53. Each diagram is shown looking physically at the side of interest, shown with the real-world image corresponding to it.

All signals on Tectonic Edge™ are 0-3.3Vdc with the exceptions of VBAT and VBUS.

## Tectonic Edge™: Top View

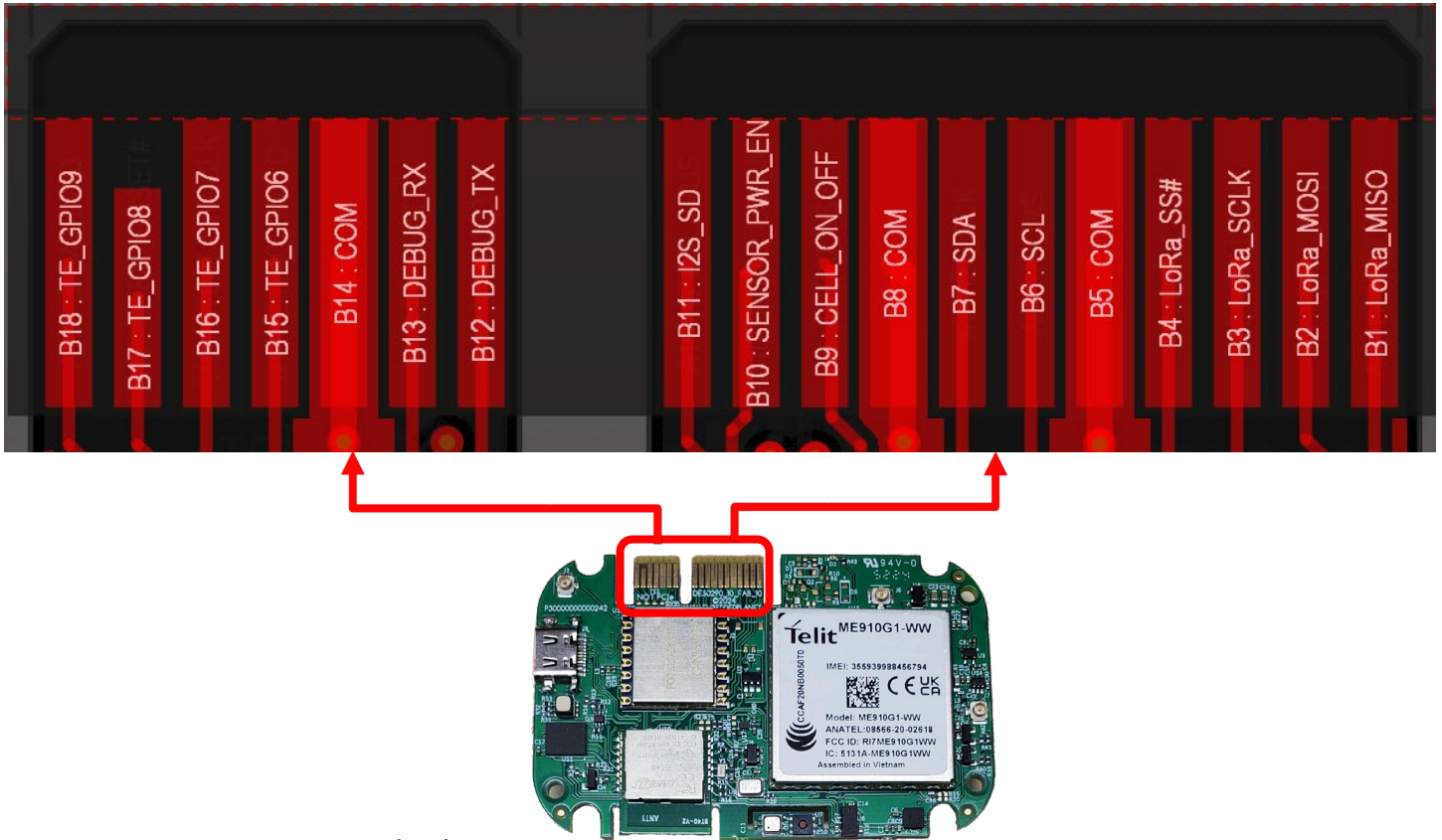

**Table 8 – Tectonic Edge Pinout (Top)**

Tectonic Edge™ Pin	Function	Connected to	Notes
<b>B1</b>	LoRa_MISO	LoRa Module	Can be used as SPI if LoRa module not present
<b>B2</b>	LoRa_MOSI	LoRa Module	
<b>B3</b>	LoRa_SCLK	LoRa Module	
<b>B4</b>	LoRa_SS#	LoRa Module	
<b>B5</b>	<b>Common</b>	<b>COM</b>	
<b>B6</b>	SCL	Sensors	
<b>B7</b>	SDA	Sensors	
<b>B8</b>	<b>Common</b>	<b>COM</b>	
<b>B9</b>	CELL_ON_OFF	Telit cell module	
<b>B10</b>	SENSOR_PWR_EN	Load Switch	
<b>B11</b>	I2S_SD	Microphone	
<b>B12</b>	Debug_TX	nRF debug UART	
<b>B13</b>	Debug_RX	nRF debug UART	
<b>B14</b>	<b>Common</b>	<b>COM</b>	
<b>B15</b>	TE_GPIO6	nRF GPIO	
<b>B16</b>	TE_GPIO7	nRF GPIO	
<b>B17</b>	TE_GPIO8	nRF GPIO	
<b>B18</b>	TE_GPIO9	nRF GPIO	

## Tectonic Edge™: Bottom View

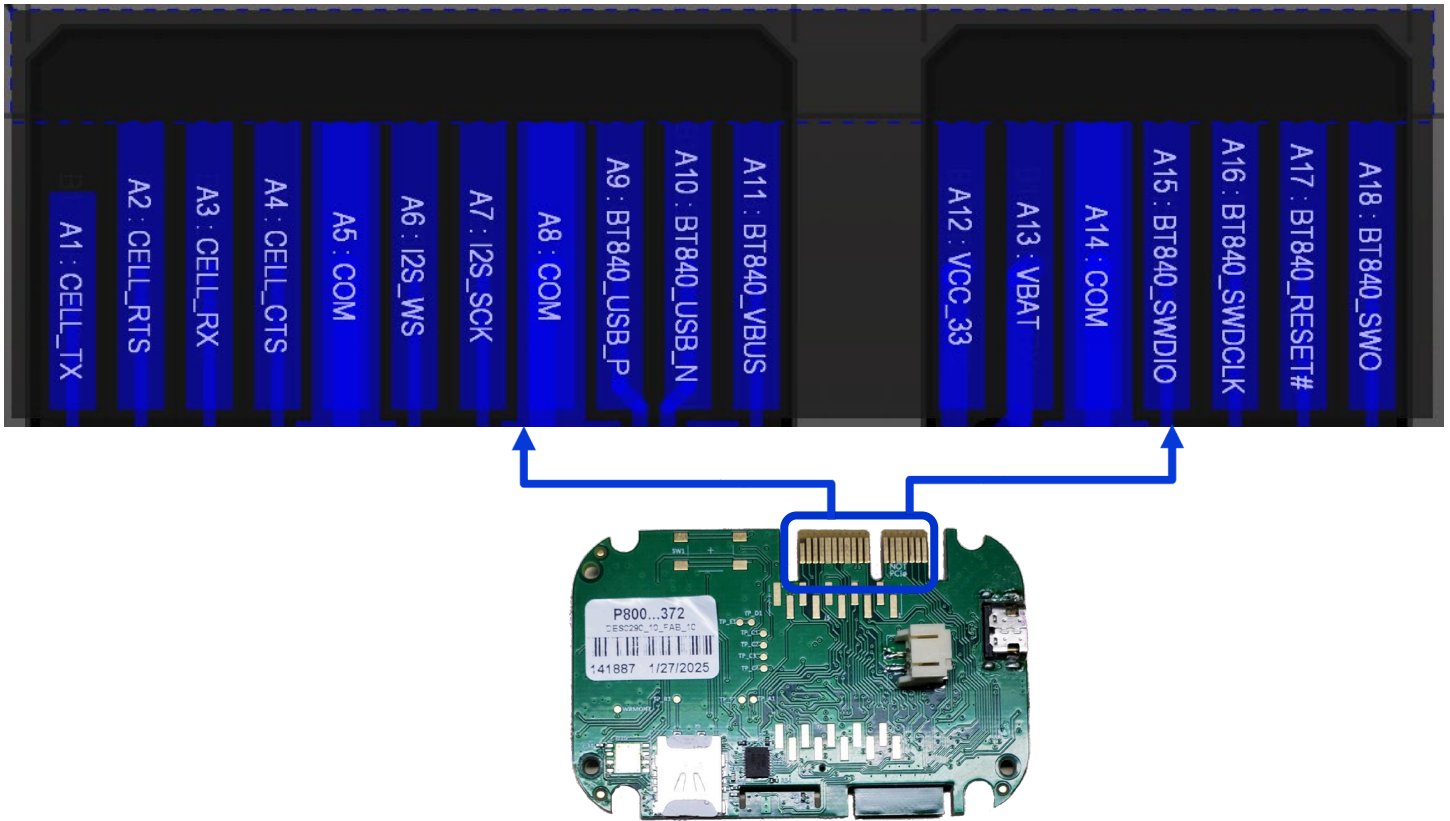
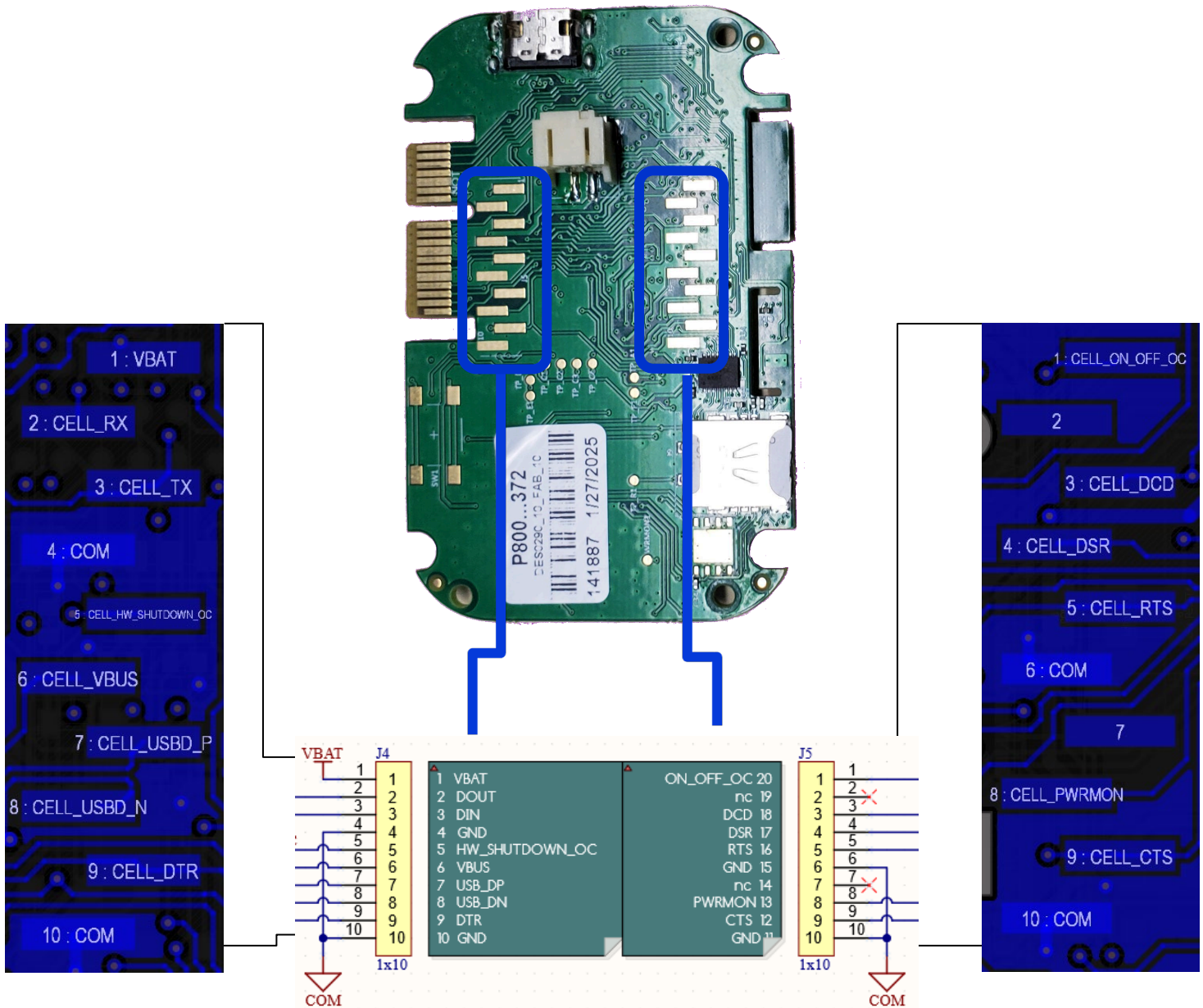

**Table 9 – Tectonic Edge Pinout (Bottom)**

Tectonic Edge™ Pin	Function	Connected to	Notes
<b>A1</b>	CELL_TX	Cell module UART	
<b>A2</b>	CELL_RTS	Cell module UART	
<b>A3</b>	CELL_RX	Cell module UART	
<b>A4</b>	CELL_CTS	Cell module UART	
<b>A5</b>	<b>Common</b>	<b>COM</b>	
<b>A6</b>	I2S_WS	Microphone	
<b>A7</b>	I2S_SCK	Microphone	
<b>A8</b>	<b>Common</b>	<b>COM</b>	
<b>A9</b>	USB_P	D+ (nRF)	
<b>A10</b>	USB_N	D- (nRF)	
<b>A11</b>	VUSB	VBUS (nRF)	
<b>A12</b>	VCC_33	3.3V out	
<b>A13</b>	VBAT	Battery voltage	
<b>A14</b>	<b>Common</b>	<b>COM</b>	
<b>A15</b>	SWDIO	Single Wire Debug	
<b>A16</b>	SWDCLK	EP Debug Header	
<b>A17</b>	nRF Reset	EP Debug Header	
<b>A18</b>	SWO	EP Debug Header	

### 13.3. Modem Header Pinout

Agora53 can be used as a drop-in modem device using the twin 1x10 pin header footprint common to modem devices. Configurations of Agora that include the population of these pin headers use a pair of 1x10-pos, 2mm pitch, SMD, male pin headers. In this format the MCU does not control the host board. Rather, the entire Agora53 acts as a cellular modem.



## 14. Antennae

The Agora53 PCBA supports three external antenna types: cellular, active GNSS and LoRa. Connections to each of the external antennae are provided onboard as u.FL connectors.



### 14.1. Antennae | Cellular Antenna

The technical requirements for the cellular antenna are given below:

Item	Value
Frequency range	Depending by frequency band(s) provided by the network operator, the customer shall use the most suitable antenna for that/those band(s)
Bandwidth	250 MHz in LTE Band 1 140 MHz in LTE Band 2, PCS1900 170 MHz in LTE Band 3, DCS1800 445 MHz in LTE Band 4 70 MHz in LTE Band 5, GSM850 80 MHz in LTE Band 8, GSM900 47 MHz in LTE Band 12 41 MHz in LTE Band 13 60 MHz in LTE Band 18 60 MHz in LTE Band 19 71 MHz in LTE Band 20 145 MHz in LTE Band 25 80 MHz in LTE Band 26 62 MHz in LTE Band 27 100 MHz in LTE Band 28 490 MHz in LTE Band 66 81 MHz in LTE Band 71 48 MHz in LTE Band 85
Impedance	50 ohm
Input power	ME910G1-W1: > 24dBm Average power ME910G1-WW: > 33dBm Average power
VSWR absolute max	≤ 10:1 (limit to avoid permanent damage)
VSWR recommended	≤ 2:1 (limit to fulfill all regulatory requirements)

In addition to the technical requirements, there are regulatory requirements that must be met.

For FCC, ISED, RED, and UKCA, the antenna must be the omnidirectional type with average gain of 2.14dBi or less.

Embedded Planet has tested the following cellular antennae:

Mounting	Mfr	Part Number	Type	Average Gain	Notes
Adhesive	Taoglas	FXUB.64.0150A	Omnidirectional	-1.5dB	

## 14.2. Antennae | GNSS Antenna

Agora53 requires an active GNSS antenna and supplies 3.0V to power the active antenna.

The technical requirements for the GNSS antenna are given below:

Item	Value
Frequency range	1559.0 ~ 1610.0 MHz
Gain	15 ~ 30dB
Impedance	50 ohm
Noise Figure of LNA	< 1.5 (recommended)
DC supply voltage	DC 1.8 ~ 3.3V
VSWR	≤ 3:1 (recommended)

Embedded Planet has tested the following GNSS antennae:

Mounting	Mfr	Part Number	Type	Gain @ 3V	Notes
Adhesive	Taoglas	AP.12F.07.0045A	2-stage active patch w/ SAW	23dB	

## 14.3. Antennae | LoRa Antenna

The technical requirements for the LoRa antenna are given below:

Frequency range: 900-940MHz

Maximum gain: 2.15dBi

Embedded Planet has tested the following LoRa antennae:

Mounting	Mfr	Part Number	Type	Peak Gain	Notes
Adhesive	Linx	ANT-916-CW-HWR-RPS	Omnidirectional	1.2dBi	

## 15. Electrical Specifications

### 15.1. Absolute Maximum & Minimum Ratings

TABLE 10 – ABSOLUTE MAXIMUM &amp; MINIMUMS

Board Pin	Min (V)	Max (V)	Notes
VBUS	-0.3	5.8	USB bus voltage
VBAT	-0.3	4.5	Main regulator input voltage
VBUS	-0.3	5.8	nRF USB
VCC	3.19	3.41	Regulated output on Tectonic Edge™
I/O pins (Tectonic Edge™)	-0.3	VCC + 0.3	System I/O pins

### 15.2. Recommended Operating Conditions

TABLE 11 – RECOMMENDED OPERATING CONDITIONS

Net	Min (V)	Typ (V)	Max (V)	Notes
CELL_VBUS	3.0	5.0	5.5	USB bus voltage to cellular module
VBAT	3.2	3.8	4.2	Power to Agora2.0
VBUS	4.35	5.0	5.5	nRF USB
VCC		3.3		Regulated output on Tectonic Edge™
I/O pins (Tectonic Edge™) and 2x10-pin headers	0	-	3.3	nRF I/O voltage must be set to 3.3V
V <sub>OH</sub>	2.9	-	3.3	Output high voltage
V <sub>OL</sub>	0	-	0.4	Output low voltage
V <sub>IH</sub>	2.31	-	3.3	Input high voltage
V <sub>IL</sub>	0	-	0.99	Input low voltage
COM	-	0	-	Reference

- *Agora53 should **never** be powered through the 3.3V VCC line.*
- ***Always** power Agora through the VBAT battery input line.*

## 16. Mechanical Specifications

### 16.1. Physical Parameters

TABLE 12 – PHYSICAL PARAMETERS

Parameter	Description	Measurement
<b>Length</b> (Fully Populated PCBA)	Board (PCBA) length	70.00 mm
<b>Width</b> (Fully Populated PCBA)	Board (PCBA) width	45.00 mm
<b>Height</b> (Fully Populated PCBA)	Board (PCBA) height <i>Including all population options (measured from LoRa antenna to power switch)</i>	16.32 mm
<b>Weight</b> (Fully Populated PCBA)	Module weight <i>Including all population options</i>	19.5 g ± 0.1 g
<b>Length</b> (PCBA In Plastics)	Module length	102.3 mm ± 0.3 mm
<b>Width</b> (PCBA In Plastics)	Module width	59.3 mm ± 0.3 mm
<b>Height</b> (PCBA In Plastics)	Module height	43.0 mm ± 1 mm
<b>Weight</b> (PCBA In Plastics)	Module weight <i>Including LiPo battery + Cell + GNSS antennae + fully populated PCBA</i>	200g

## 16.2. Environmental Specifications

---

TABLE 13 – ENVIRONMENTAL SPECIFICATIONS

Parameter	Min	Typ	Max
Operating Temperature	-40°C	+25°C	+85°C
Storage Temperature	-40°C	+25°C	+85°C
Operating Humidity, non-condensing	20% RH		90% RH

## 17. Regulatory Information

---

### 17.1. Cellular Certifications & Endorsements

---

#### Certifications

---

**PTCRB:**

ID 131153, granted 19 MAY 2025

<https://iotnetworkcertified.com/certified-device-details/?model=60477>



**AT&T TRENDI:**

Passed 21 MAY 2025

[AT&T Certified Device Listing](#)

**T-Mobile DICE**

In process

**Verizon ODI:**

In process

### 17.2. RoHS Compliance

---

The Agora device complies with the RoHS (Reduction of Hazardous Substances) directive of the European Union, EU Directive 2011/65/EU.

### 17.3. Interference Statement

---

This equipment has been tested and found to comply with the limits for a Class B digital device, pursuant to part 15 of the FCC Rules. These limits are designed to provide reasonable protection against harmful interference in a residential installation. This equipment generates, uses, and can radiate radio frequency energy and, if not installed and used in accordance with the instructions, may cause harmful interference to radio communications. However, there is no guarantee that interference will not occur in a particular installation. If this equipment does cause harmful interference to radio or television reception, which can be determined by turning the equipment off and on, the user is encouraged to try to correct the interference by one or more of the following measures:

- Reorient or relocate the receiving antenna.
- Increase the separation between the equipment and receiver.
- Connect the equipment into an outlet on a circuit different from that to which the receiver is connected.

—Consult the dealer or an experienced radio/TV technician for help.

## 17.4. FCC and ISED Compliance

Agora53 contains three radio transmitters – Bluetooth, cellular and LoRa – all under the control of the MCU. Any firmware written for the MCU on Agora must control the three radio transmitters such that no more than one radio is transmitting at any given time.

The Bluetooth antenna is onboard; the cellular and LoRa antennae are off board.

If the antennae for the Agora53 device are located farther than 20cm from the human body and there are no adjacent transmitters, the FCC and ISED approvals of the device’s radio transmitter module can be reused by the end product.

If any of the antennae is mounted closer than 20cm from the human body, or if there are adjacent transmitters, additional FCC/ISED testing may be required for the end device.

Radio Module Type	FCC ID	ISED ID
Bluetooth	X8WBT40F	4100A-BT40F
LoRa	2AD66-1276C1	21278-1276C1
Cellular: LTE CAT M1/NB2	RI7ME910G1WW	5131A-ME910G1WW

## 17.5. Wireless Notice

The Agora53 device complies with FCC/ISED radiation exposure limits set forth for an uncontrolled environment and meets the FCC radio frequency (RF) Exposure Guidelines and RSS-102 of the ISED radio frequency (RF) Exposure rules. This transmitter must not be co-located or operated in conjunction with any other antenna or transmitter. The antenna should be installed and operated with a minimum distance of 20 cm between the radiator and your body.

## 17.6. External Antenna Requirements: LoRa

The Agora53 radio transmitter has been approved by the FCC & ISED to operate with the antenna types listed below with the maximum permissible gain indicated. Antenna types not included in this list, having a gain greater than the maximum gain indicated for that type, are strictly prohibited for use with that device.

TABLE 14 – FCC & ISED MAX GAIN BY BAND

Antenna Gain: 2.15 dBi (Omnidirectional type)
---

## 17.7. External Antenna Requirements: Cellular

The Agora53 radio transmitter has been approved by the FCC & ISED to operate with the antenna types listed below with the maximum permissible gain indicated. Antenna types not included in this list, having a gain greater than the maximum gain indicated for that type, are strictly prohibited for use with that device.

TABLE 15 – FCC & ISED MAX GAIN BY BAND

Antenna Gain: 2.14 dBi (Omnidirectional type)
---

## 17.8. End-Product Labeling Requirements

---

When Agora53 is used in any host assemblies, the OEM host end product manufacturer must display a label on the exterior of the assembly referring to the enclosed module. The exterior label will read as follows:

**Device Uses Approved Radio: ME910G1-WW**

**Contains FCC ID: X8WBT40F**

**Contains ISED ID: 4100A-BT40F**

**Contains FCC ID: 2AD66-1276C1**

**Contains ISED ID: 21278-1276C1**

**Contains FCC ID: RI7ME910G1WW**

**Contains ISED ID: 5131A-ME910G1WW**

**This device complies with part 15 of the FCC Rules. Operation is subject to the following two conditions: (1) This device may not cause harmful interference, and (2) this device must accept any interference received, including interference that may cause undesired operation.**

## 17.9. FCC Additional Testing, Part 15 Subpart B Disclaimer

---

The modular transmitter is only FCC authorized for the specific rule parts (i.e., FCC transmitter rules) listed on the grant, and that the host product manufacturer is responsible for compliance to any other FCC rules that apply to the host not covered by the modular transmitter grant of certification. If the grantee markets their product as being Part 15 Subpart B compliant (when it also contains unintentional-radiator digital circuitry), then the grantee shall provide a notice stating that the final host product still requires Part 15 Subpart B compliance testing with the modular transmitter installed. The end product with an embedded module may also need to pass the FCC Part 15 unintentional emission testing requirements and be properly authorized per FCC Part 15.

## 18. Revision History

---

**TABLE 16 – REVISION HISTORY**

Revision	Author	Description	Date
0.1	M. Leopold	Initial Release	12 MAY 2025
0.2	M. Leopold	Added regulatory compliances	19 MAY 2025
0.3	M. Leopold	Updated website information; formatting	20 JAN 2026
0.4	M. Leopold	Typo corrections, added orderable part numbers	02 FEB 2026

## Contact Embedded Planet

---

Embedded Planet  
31225 Bainbridge Rd, Suite N  
Solon, OH 44139  
Phone: 216.245.4180  
[www.embeddedplanet.com](http://www.embeddedplanet.com)

## Company Email

---

Sales: [sales@embeddedplanet.com](mailto:sales@embeddedplanet.com)  
Information Requests: [info@embeddedplanet.com](mailto:info@embeddedplanet.com)  
Technical Support: [support@embeddedplanet.com](mailto:support@embeddedplanet.com)